



PRO-MAX 14" TWO-SIDED GRILLS

MODELS PGT14, PGT14I, PGT14T, PGT14IT, PGE14IE,
PST14, PST14I, PST14T, PST14IT, PSE14IE

ALUMINUM, IRON, GROOVED & SMOOTH

FEATURES/BENEFITS

- Expand your menu with Star's Pro-Max two sided grill. Prepare "Panini" sandwiches, chicken breasts, hamburgers, steaks, wraps, vegetables and many other menu items quickly and easily while maximizing space.
- NEW lower profile and aesthetics.
- NEW optional electronic control is rated from 175°F (79°C) to 550°F (302°C) and has 4 countdown timers.
- Standard dial thermostat is rated from 175°F (79°C) to 550°F (302°C) and provides accurate sensing of temperature.
- Heavy-duty aluminum & iron platens provide long life and superior performance for high volume operations.
- A heavy-duty commercial hinge system and handle provides safe and effortless operation of the top platen.
- Two-sided cooking heats your menu items in half the time, sealing in flavor.
- The bottom platen has a patented splash guard to help keep products and grease in their place.
- Ergonomically designed control panel provides easy access and visibility to controls and grease drawer.
- Heavy gauge, water resistant flexible plastic conduit protects electrical connections.
- Electronic controls with multi channel countdown display.
- Removable grease drawer in the front of unit for easy clean-up.
- Top platen leveling system lifts top platen parallel to bottom platen for a full 3 inches before rotating up, providing even cooking of thin tortillas to thick panini sandwiches and burritos.

Application:

Two-Sided Grills can prepare sandwiches, chicken breasts, wraps, hamburgers and a variety of other menu items in your restaurant, cafe, concession stand, bar, or wherever you need high performance cooking. Grills are compact and portable providing flexibility in your operation.

Quality Construction:

Star's Two-Sided Grills are constructed of 18 gauge stainless steel. Units available with aluminum, iron grooved or smooth platens. Star's heavy-duty hinge mechanism is constructed of hardened aluminum for strength and durability. Metal tubular elements are standard. The lead-in cord is resistant to water and oil to protect wiring. Furnished with a 6' cord and standard NEMA plug. Other plugs available upon request.

Warranty:

Star's two-sided grills are covered by a **one year** parts and labor warranty.



Model PGT14



Model PST14



Pro-Max 14" Two-Sided Grills





PRO-MAX 14" TWO-SIDED GRILLS

MODELS PGT14, PGT14I, PGT14T, PGT14IT, PGE14IE,
PST14, PST14I, PST14T, PST14IT, PSE14IE

ALUMINUM, IRON, GROOVED & SMOOTH

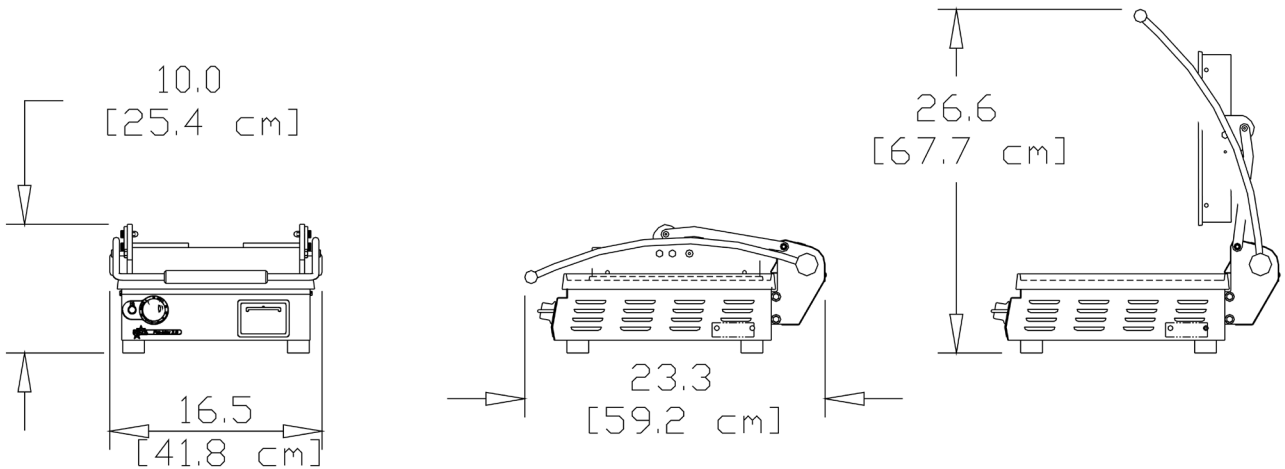

Model and Specifications

Series No.	ALUMINUM		IRON PLATENS		Width	Depth	Height	Ship Wt.	Freight Class
	Voltage	Watts	Voltage	Watts					
PGT14	120	1,800	208/240	2,700/3,600	19.6	23.3	26.6 - closed 10.0 - open	75lbs - Aluminum 101lbs - Iron	85
PST14	208/240	1,800 (CSA) 1,350/1,800							

3 - NEMA 5-15P plug standard for 120V applications. 5-20P for CSA

NEMA 6-20P plug standard for 208 & 240V applications over 3600 Watts

NEMA 6-30P plug standard for 208 & 240V applications over 3600 Watts

All models available in 230V

Typical Specifications

Two-Sided Grills are constructed with an 18 gauge stainless steel body. Aluminum platens are standard. A hinge mechanism provides easy operation for the top platen. Grilling height between platens is up to 3". Metal sheathed tubular elements shall be provided as standard. Non-skid feet shall be standard. Unit shall be provided with six foot power cord with Nema rated plug (see specifications above). Units carry approval of UL, UL Sanitation or UL Canada Standards. Printed in the U.S.A.

Due to periodic changes in designs, methods, procedures, policies and regulations, the specifications contained in this sheet are subject to change without notice. While Star Manufacturing exercises good faith efforts to provide information that is accurate, we are not responsible for errors or omissions in information provided or conclusions reached as a result of using the specifications. By using the information provided, the user assumes all risks in connection with such use.

Star Manufacturing International Inc. - 10 Sunnen Drive - P.O. Box 430129 - St. Louis, MO 63143-3800

Phone: (800) 264-7827 - Fax: (800) 264-6666 - www.Star-Mfg.com